

UC300

Mach3 CNC Motion Controller Users Manual V2



All copyrights reserved
Shall not be reproduced without permission.

Contents

1. Brief Description of the UC300 Motion Controller	1
2. Safety Notes	1
3. Physical Installation of the device	2
4. Controller UC300 Power Solution	3
5. Wiring and Ports Description	4
5.1 Ethernet Communication Interface to PC	5
5.2 Stepper/Servo Motor Control Interface Connection	5
5.3 Spindle Control Output Port	6
5.4 General output interface	7
5.5 Function Switch for MPG and Connection for MPG	9
5.6 Input Ports	10
5.7 Adjustable Input Interface	12
5.8 Power Supply for Controller System and Power Supply for IO Port	13
5.9 LEDs Indicator for Power and communication with Mach 3 software	13
6. Mach 3 Configuration	14
6.1 PlugIn	14
6.2 Open Mach3 Software and connect with right PlugIn file	14
6.3 Check UC300 Plug-In in the Mach3 software	15
6.4 Motor Tuning and Setup	16
6.5 Port and Pins Setup	17
6.6 MPG Settings	20

1. Brief Description of the UC300 Motion Controller:

For firstly of all we thank you for your interesting in our product and for reading this user's guide.

The UC300 is a high-performace external motion controller for Mach3, with USB port communicated Mach 3 software,supporting standard MPG and Digital Dream MPG.The device can communicate with a connection to a control computer's network.The network connection can be built with direct connection by USB Port.

The computer connects to the UC300 via a standard USB cable.It's the best to shiled the communication USB cable to ignore the interferences.

The device can be used to control machine tools with stepper or servo motor with pulse and direction interface;the controller can output a maximum of 300kHz stepping frequency for each axes and can work with upto 6-axes.The Controller is 3-6 Axis for user's options.

This user's guide describes how to establish connection between the device and controler computer,the device and stepper/Servo drives and spindle motor,how to setup the network and the device for the communication.This document also describes the inputs and outputs,the electrical parameters and properties of the motion controller.It guides the users how to run the device with Mach3 software,and how to set the parameters in the software.

Here is the brief description for the device:

- 1) Motion control 3-6 Axis(X,Y,Z,A,B,C) for option,max frequency output 300Khz/Axis;
- 2) USB Communication with Mach 3 Software;
- 3) Main power supply 24VDC,Current should higher than 1A;
- 4) IO Power is 24VDC power supply input,current should higher than 1A(The controller already supply the power for IO port,no need the external power supply for IO port anymore);
- 5) 12 opto-isolated digital input ports,10 opto-isolated digital output ports;
- 6) 1 analog output port of 0-10V adjustable speed for spindle (can change to PWM output port);
- 7) ARM motion control chip;
- 8) Compatible with Standard MPG and also Digital Dream MPG

Accessories:

Beside the main products,in our package,there are accesories: 1pcs 1.5meter USB cable.

2. Safety Notes:

Moving objets like machine tool axes and automatical equipments can be very dangerous.Always make sure to keep all machines safety standards.Always install E-stop switches and the required safety equipments to your control system and make sure that the equipment controlled by our device meets all the safety standards.

Always keep the controller dry and away from falling chips and dust,protect the device from taint damage.Avoid conneciton mistakes,avoid high voltage damage,avoid operation errors.

Protect the device from direct intensive sunshine beams and from extreme temperature levels and from extra high humidity weather.

We cannot take the responsibility for any persernal injury and financial loss caused by any device failure or caused by following an error in this documentation.

3. Physical Installation of the device(Unit:mm)

The UC300 motion controller is with the sealed shell structure,there are 4pcs mounting holes around the controller.We can fix 4pcs 4mm diameter holes at the cabinet,and install the controller into the cabinet.

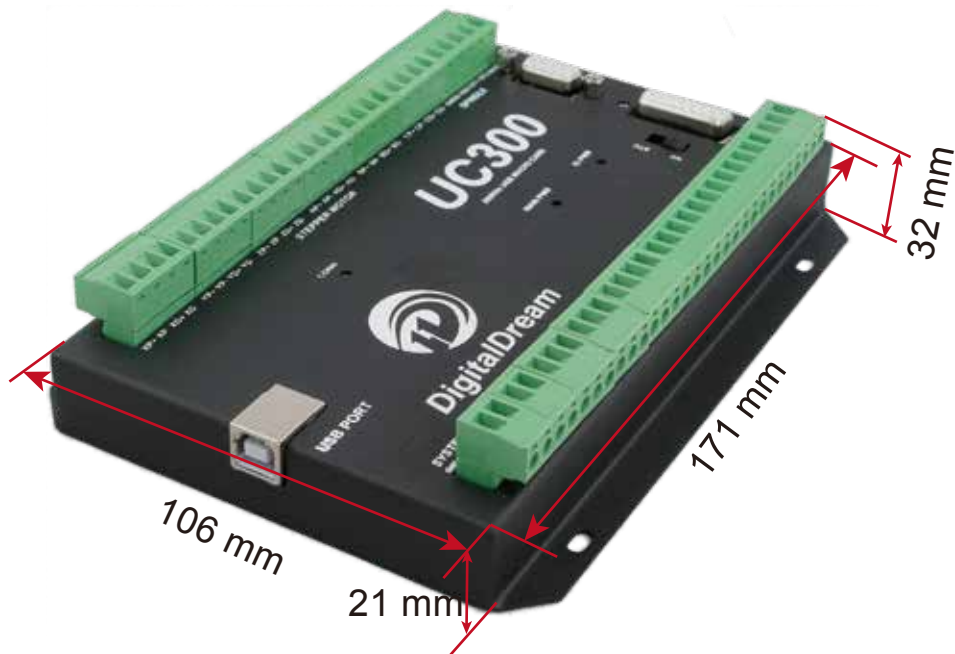

Figure 3-1 UC300 Front Appearance and size

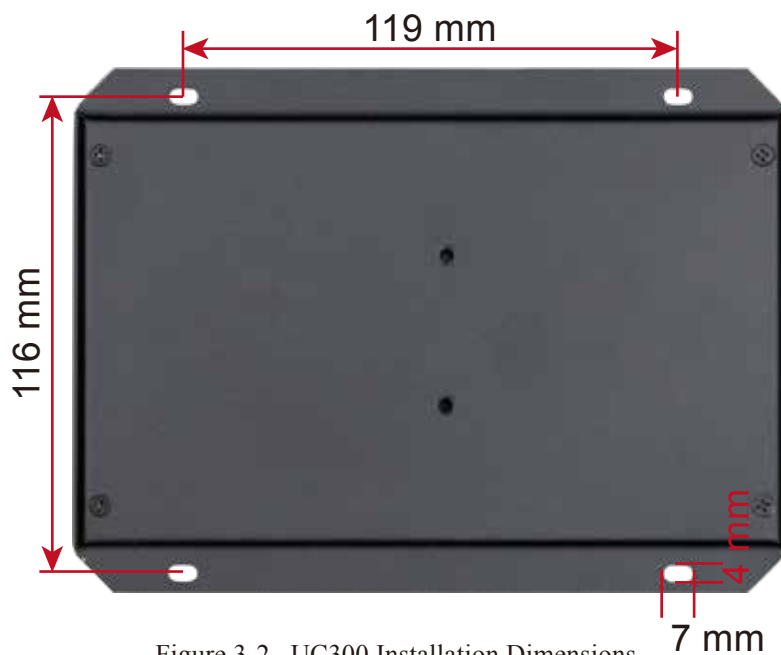

Figure 3-2 UC300 Installation Dimensions

4. Controller UC300 Power supply Solution

The power supply solution in the field of the Industrial automation is always very complicated, there is a lot of the GND, now we describe the structure of the power structure as below:

The power structure as the Figure 4-1, Power supply input and USB port share common GND, stepper control module, Input&Output module, Spindle control module and MPG Port share common GND, between the two sector there is photoelectric isolation. Inside of the board, there is GND as common-.

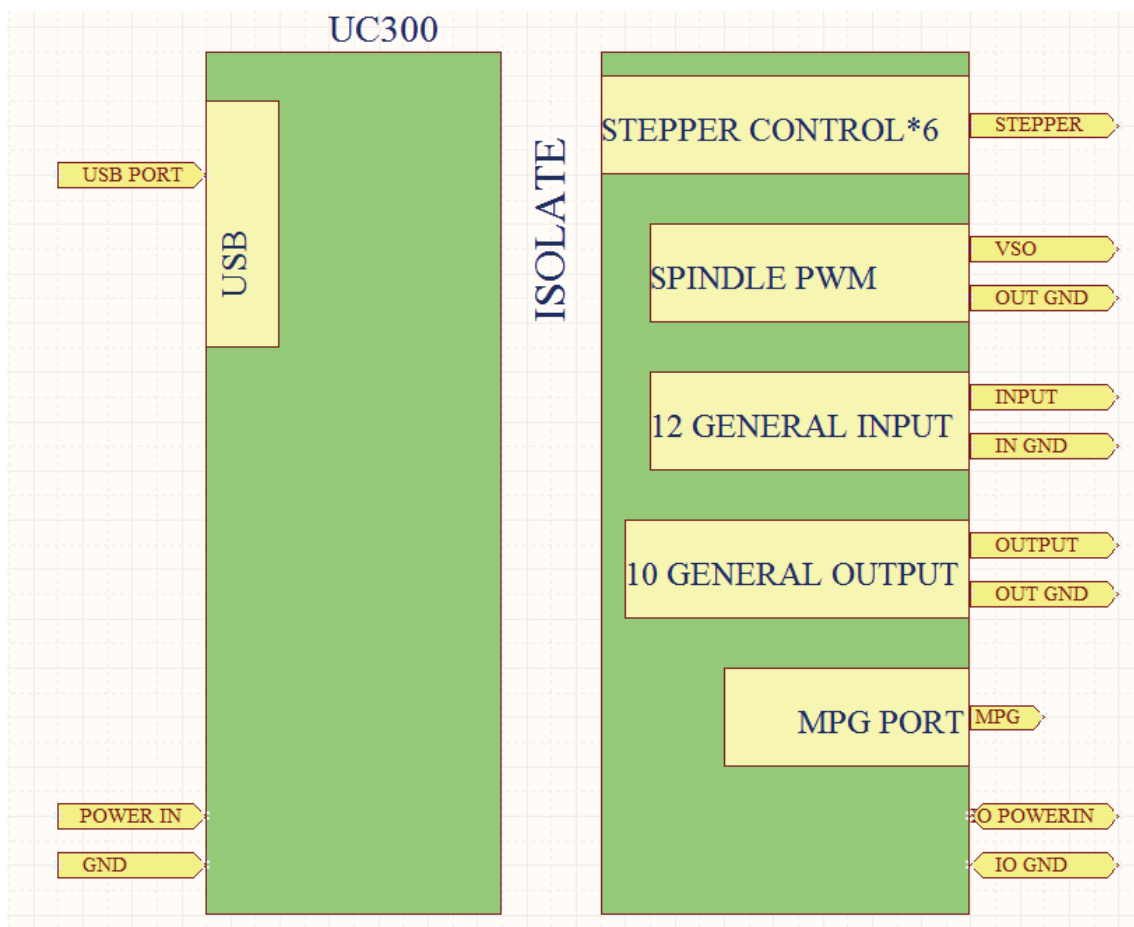

Figure 4-1 UC300 Power supply structure

5. Connection Guide

The following drawing shows the main connections of our device. We will describe one by one in next pages. Here are:

- 1 : USB Communication Interface to PC
- 2 : Stepper/Servo motor Driver connection port
- 3 : Spindle Control Output Port
- 4 : General Output Interface
- 5 : MPG Port
- 6 : Functional Switch for MPG: Standard MPG or Digital Dream MPG
- 7 : Serial Extend Port
- 8 : Input Port: Limit/Home/Probe and so on
- 9 : Adjustable parameter Input Port
- 10 : Main System and IO Power Port

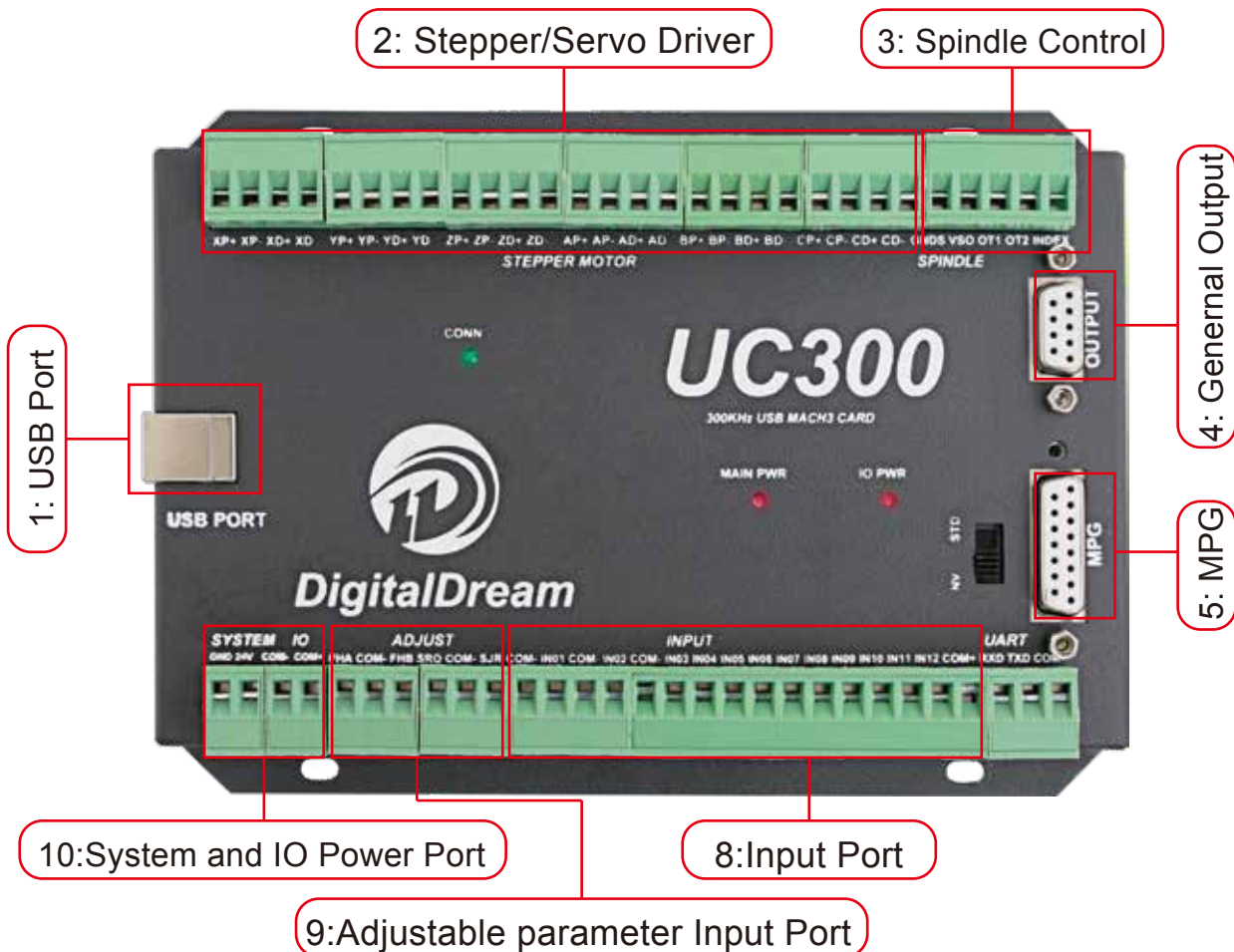

Figure 5-1 UC300 Wiring Over-view

5.1 USB Communication Port to PC

To setup the connection between the controller and the Mach3 software on computer,UC300 use the USB port,as the Marked No.1 on Figure 5-1.

5.2 Stepper/Servo Motor Control Interface Connection



As the Marked No. 2 from Figure 5-2,there is the Stepper/Servo Interface.The device can be used to control machine tools with stepper or servo motor controls with pulse and direction signals.The option for users is 3-6 axis.

Motor Driver Connection(5V)	
PIN Mark	Description
XP+	X Axis Pulse Output +
XP-	X Axis Pulse Output -
XD+	X Axis Direction Output +
XD-	X Axis Direction Output -
YP+	Y Axis Pulse Output +
YP-	Y Axis Pulse Output -
YD+	Y Axis Direction Output +
YD-	Y Axis Direction Output -
ZP+	Z Axis Pulse Output +
ZP-	Z Axis Pulse Output -
ZD+	Z Axis Direction Output +
ZD-	Z Axis Direction Output -
AP+	A Axis Pulse Output +
AP-	A Axis Pulse Output -
AD+	A Axis Direction Output +
AD-	A Axis Direction Output -
BP+	B Axis Pulse Output +
BP-	B Axis Pulse Output -
BD+	B Axis Direction Output +
BD-	B Axis Direction Output -
CP+	C Axis Pulse Output +
CP-	C Axis Pulse Output -
CD+	C Axis Direction Output +
CD-	C Axis Direction Output -

Figure 5-2 UC300 Stepper/Servo Mark and description

5.3 Spindle Control Output Port

As Figure 5-1 showed, No.3 terminal block is for Spindle control output. We define the interface from left are GNDs, VSO, OUT1, OUT2, Index. They are Ground of output, Speed adjusting voltage, Digital output1, Digital output2, Spindle speed feedback input.

Take Nowforeuer inverter as the example. Spindle control output and the inverter connection showed as Figure 5-6. X1 control spindle Clockwise RUN and STOP, AIN1 modify spindle's speed. if we need to control spindle anti-clockwise RUN and STOP, we need to connect X2 to OUT2.

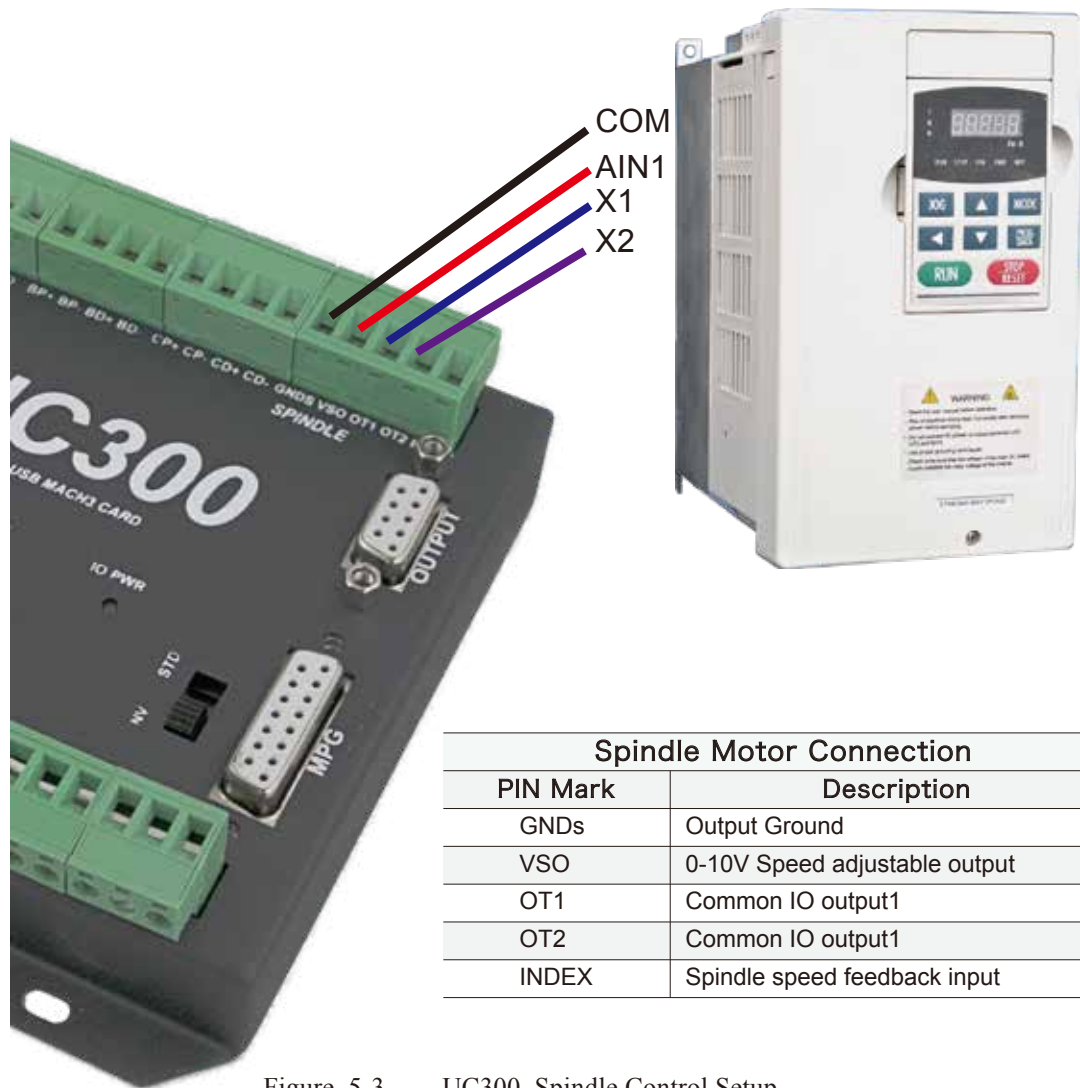

Figure 5-3 UC300 Spindle Control Setup

VSO connects to Speed adjustment which defined by voltage 0-10V.

The relationship Max. Spindle speed and current spindle speed is as below:

$$VSO(\text{Output Voltage}) = 10 * \text{current spindle speed}(S) / \text{Maximum Spindle Speed}(\text{Max}.S).$$

For example if we set the Max Speed is 24000, and we need the current spindle speed is 18000, then $VSO = 10 * 18000 / 24000 = 7.5V$.

The following Figure 5-7 is the setting method of Max. speed in Mach3 software.



Figure 5-4 UC300 Spindle Motor Max Speed Setting

5.4 General output interface

As the Figure 5-1 showed, the marked No. 4 is General output interface. This is a DB9 port.

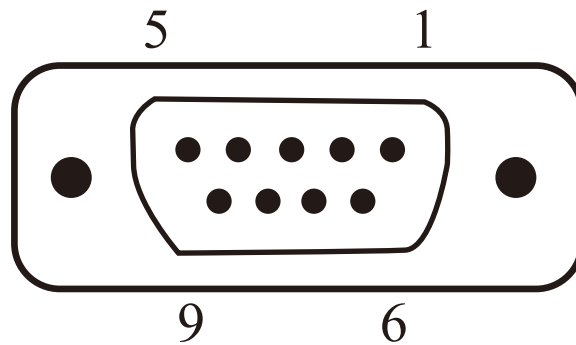

Figure 5-5 General Output Interface

PIN No.	Mark	Definition
1	GND	Common Ground for output
2	OUT4	OUTPUT 4
3	OUT6	OUTPUT 6
4	OUT8	OUTPUT 8
5	OUT10	OUTPUT 10
6	OUT3	OUTPUT3
7	OUT5	OUTPUT5
8	OUT7	OUTPUT7
9	OUT9	OUTPUT9

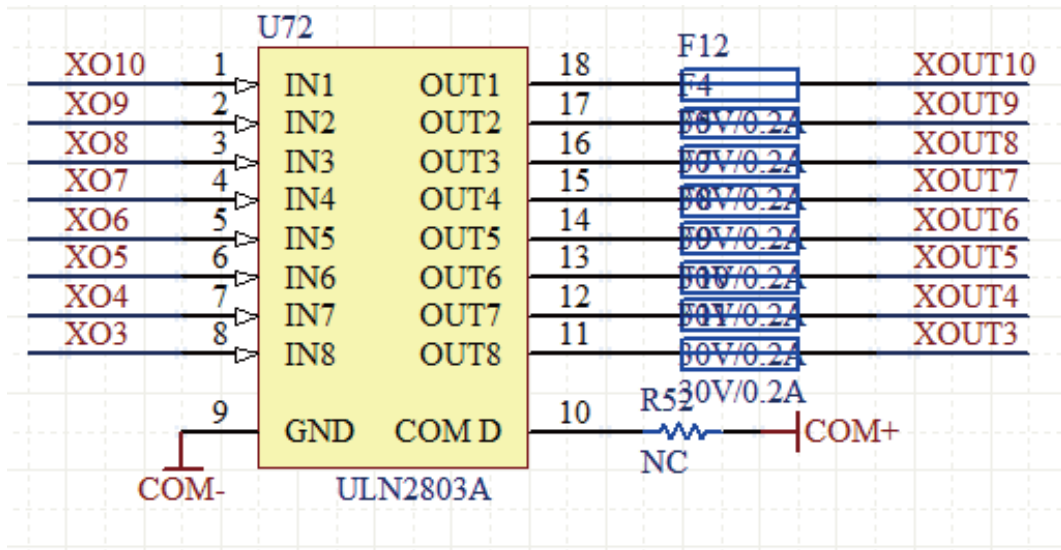

Figure 5-6 OUTPUT port internal structure

The general output interface has a built-in relay drive circuit, which can be directly connected to less than the 100mA relay. Reference Figure 5-6 for wiring with relay, using output 4(Pin No.2) and COM+.By the connection method of Figure 5-6,it is the controller supply the power for the Output Ports.If the users want to supply the external power for the relay,then the connection is between GND(Pin1) and Output4(Pin2).

GND is COM-.

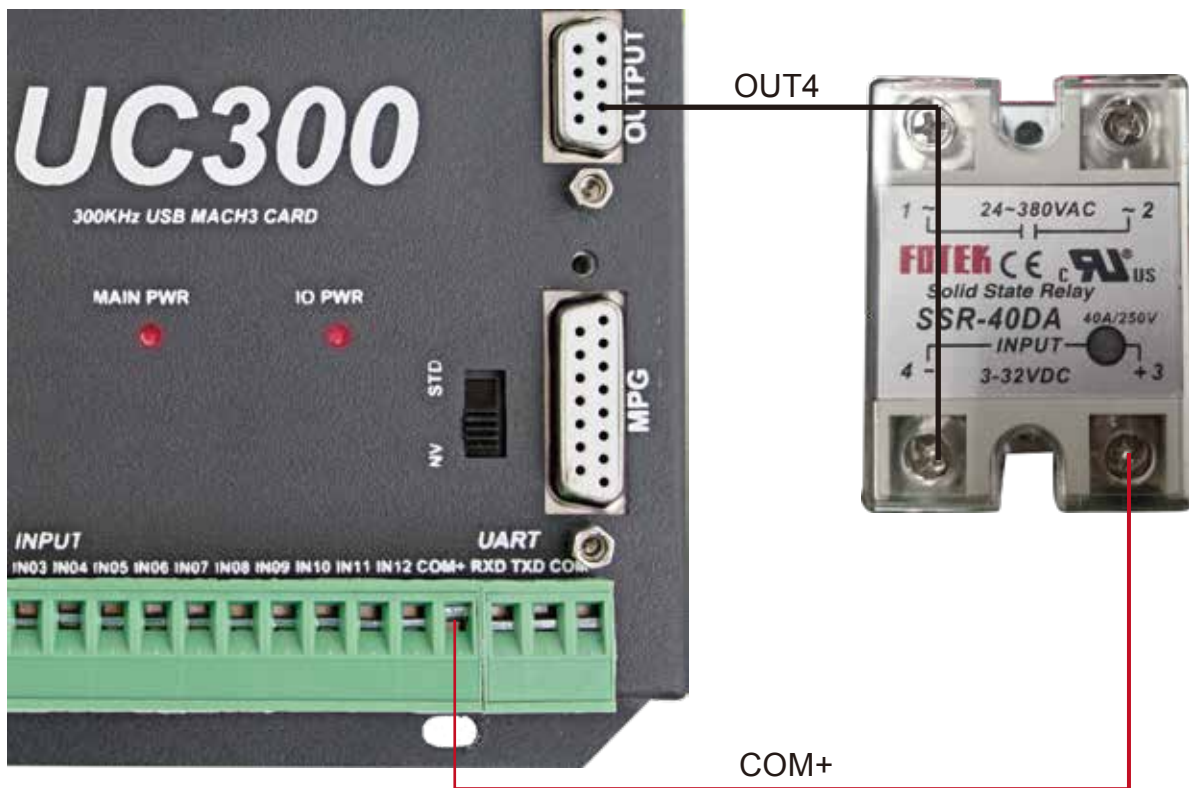
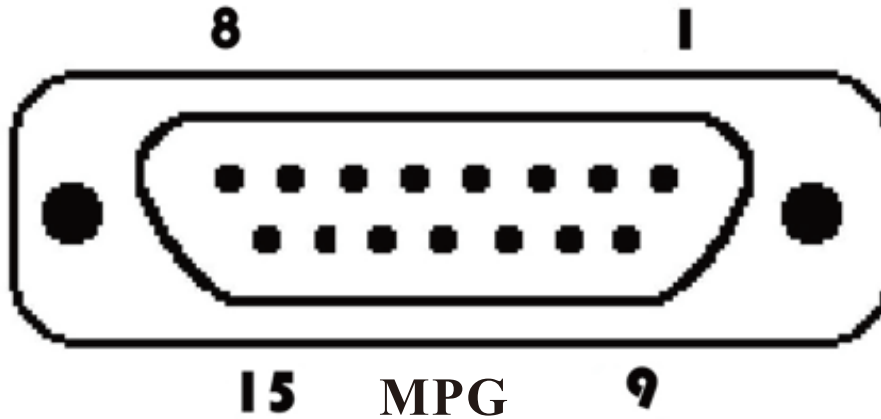

Figure 5-7 Solid Relay Connection

5.5 Function Switch for MPG

As the Figure 5-1 showed, the marked No.5 is the DB15 interface for MPG output signals.

Please Note that the UC300 only support Standard MPG.



PIN No.	Mark	Definition
1	T1OUT	TXD of Serial port
2	VMPG	Power supply + for MPG(5V)
3	WHA+	A phase positive of the encoder
4	WHB+	B phase negative of the encoder
5	XIN	X axis select input
6	ZIN	Z axis select input
7	X100IN	100 rate select input
8	EP	Estop port
9	R1IN	RXD of Serial port
10	GND	Ground and common end
11	WHA-	A phase positive of the encoder
12	WHB-	B phase negative of the encoder
13	YIN	Y axis select input
14	AIN	A axis select input
15	X10IN	10 rate select input6

5.6 Input Ports

As the Figure 5-1 showed, Marked No. 8 position is for Input ports. They are the optical isolated Input interface. The Definition from left to right is COM-, IN01, COM-, IN02, COM-, IN03, IN04, IN05, IN06, IN07, IN08, IN09, IN10, IN11, IN12, COM+ . Internal structure see as Figure 5-9.

2 lines Proximity Switch/ordinary fretting switch / drawing see as Figure 5-10.

3 lines Proximity Switch connection Figure 5-11 and Figure 5-12, brown cable for Proximity switch connect with COM+, Black cable connect channel, blue cable connect with COM-. Pls note Only support NPN type 3 lines proximity switch.

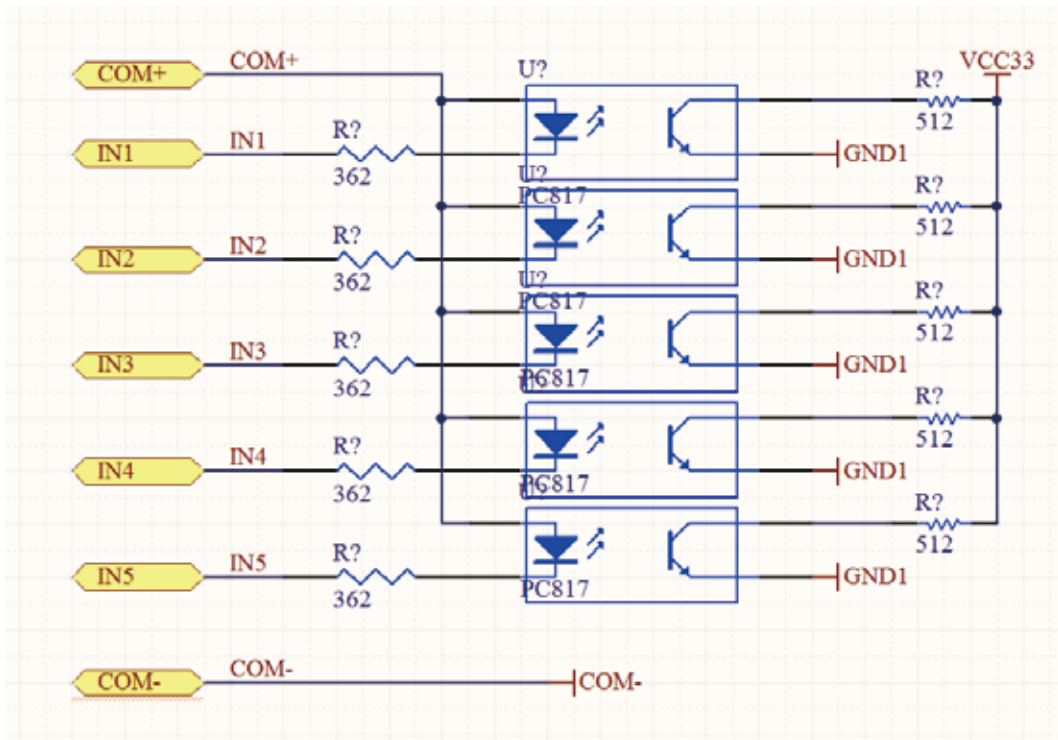

Figure 5-9 Internal structure of Input interface

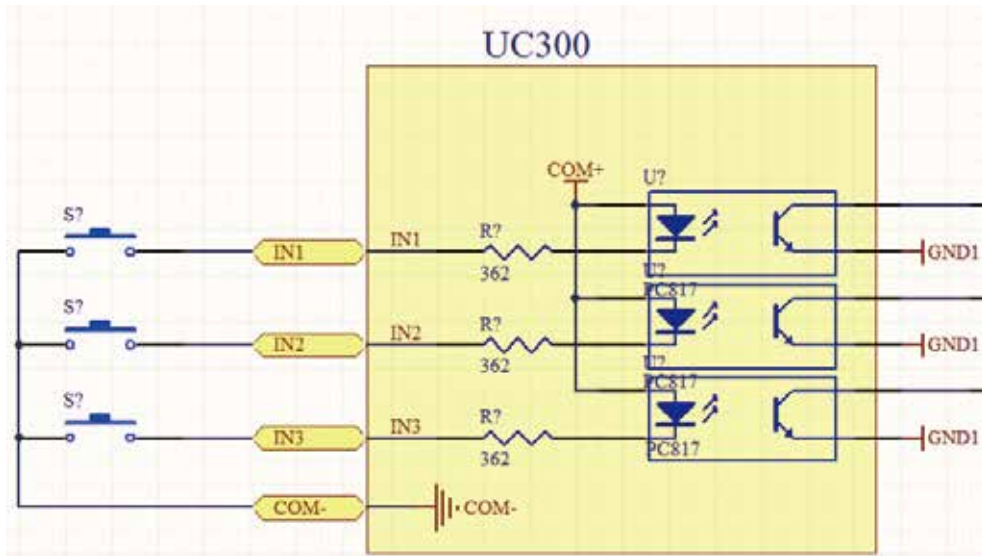

Figure 5-10 Probe/Estop/ and other switch input connection

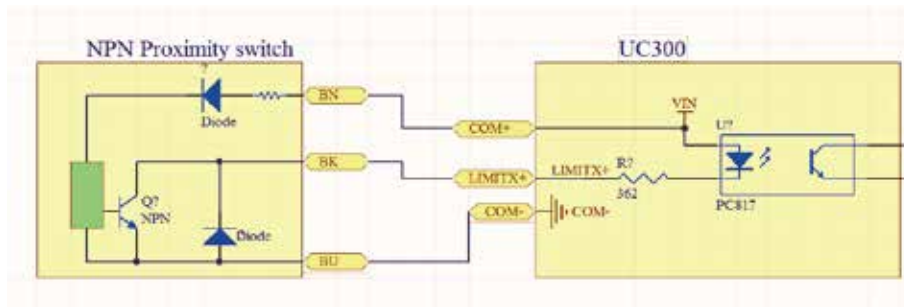

Figure 5-11 Probe/Estop/ and other switch input connection

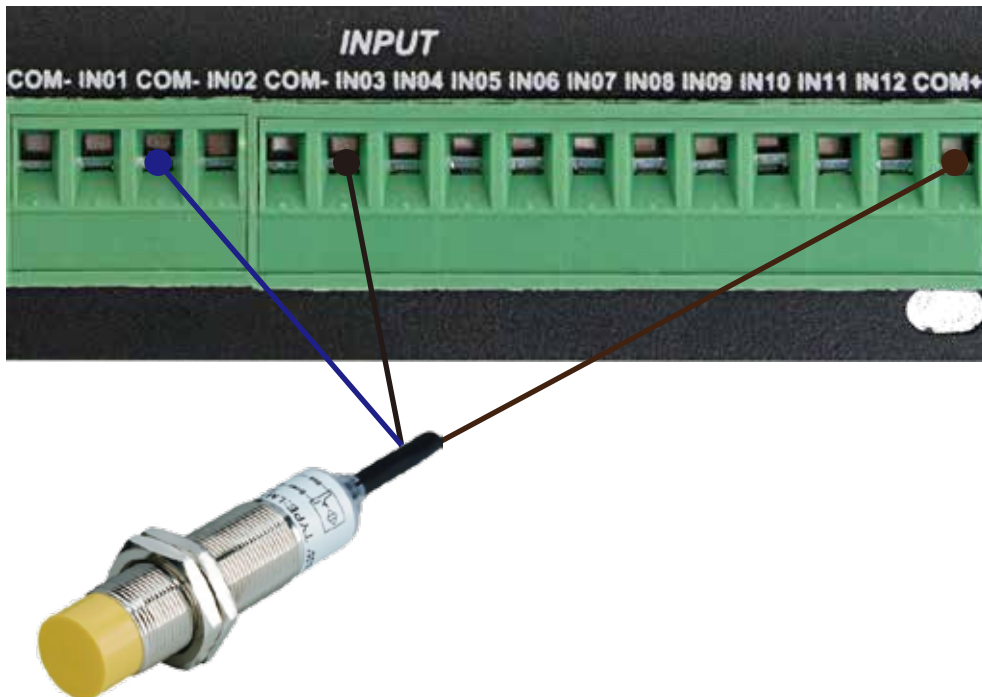
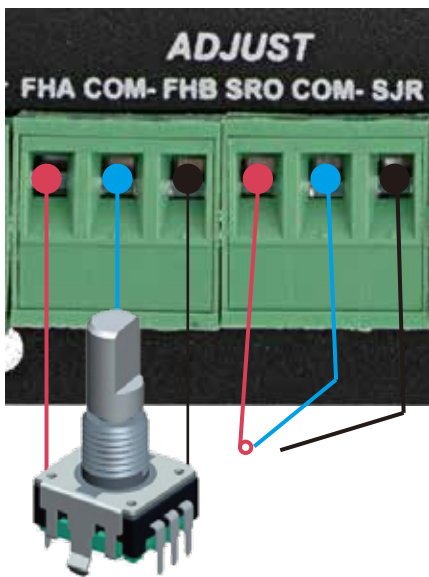

Figure 5-12 NPN 3 lines Proximity Switch Connection Example

5.7 Adjustable Input Interface



From the Figure 5-1 shows, the Marked No. 9 is for adjustable input interface, which must be operated by the digital potentiometer. The interface will make us to operate the FRO, SRO and SJR very Easy and convenient. The Interface should be operated with position switch and digital potentiometer, for the FRO, SRO and SJR adjustment.

Adjustable Inputs	
PIN Mark	Description
FHA	Potentiometer Phase A
COM-	Comman Ground
FHB	Potentiometer Phase B
SRO	Spindle Speed Override
COM-	Comman Ground
SJR	Jogging Mode

If there is no connection between COM- and SRO or COM- and SJR, the default is FRO Active, it means it is in the term of 'Feed rate override'. When there is connection between COM- and SRO, it is in the terms of 'Spindle speed rate override'; if there is connection between COM- and SJR, it is in the term of 'Jog Mode'.

5.8 Power Supply for Controller System and Power Supply for IO Port

As the Figure 5-1 show, The marked No. 9 port is the power supply port for IO port, and Marked No. 10 is for the power supply for Controller System. The access voltage range is 24VDC, and the power demand is not less than 20W. As shown in the Figure, the left terminal is power - and the right terminal is power +, they shared one common GND. See the Figure 5-13 as below:

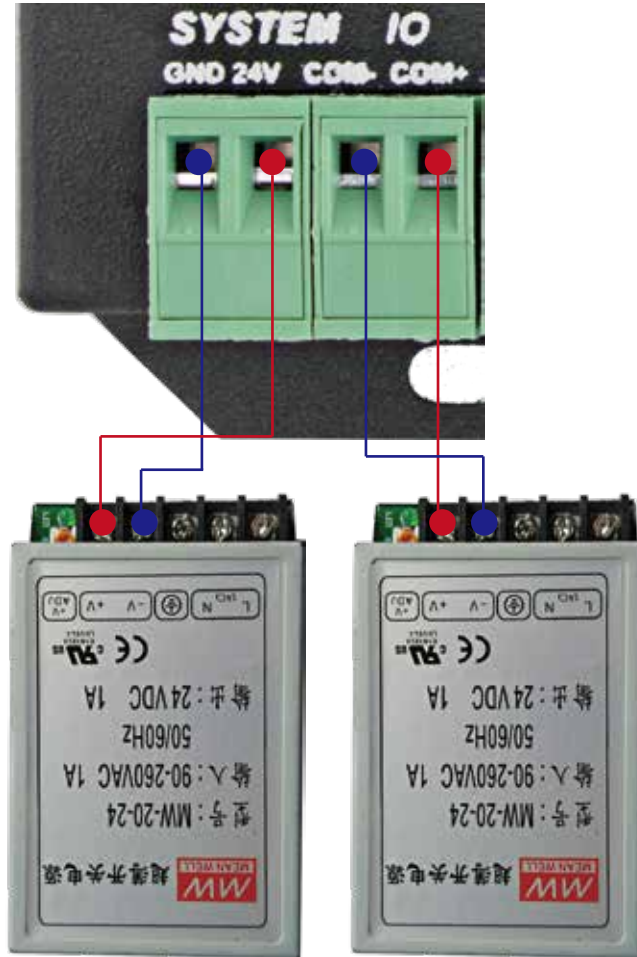

Figure 5-13 Power supply for Controller System and for IO Port

5.9 LED Indicator for Power and communication with Mach 3 software

As the Figure 5-1 show, There are 3 Indicator LEDs for the controller power, IO Power and communication with Mach3 respectively.

If the controller and IO power supply are configured in right way, the Main Power LED and IO Power LED turn to Red.

The LED marked “CONN” represents the status of the communication with Mach3 software. If a link has not been established, the LED will not light.

6. Mach 3 Configuration

6.1 PlugIn

When you purchase our product, we will supply a software package in the U-disk, which contains “DigitalDream” PlugIn, and the UC300 Manual.

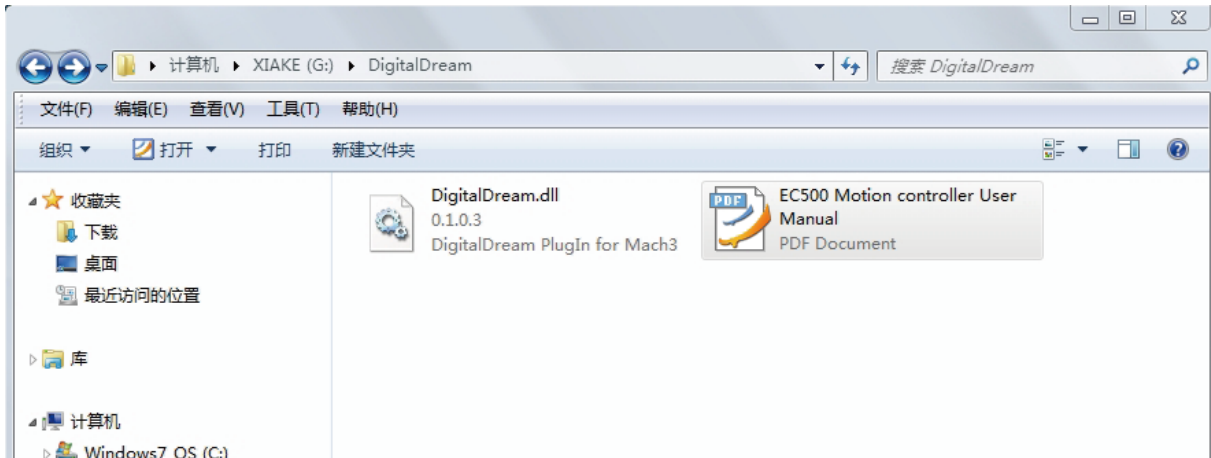

In your computer which you will run the UC300 controller, you must already installed the Mach 3 Software, and now pls copy the PlugIn in to C:\Mach3\PlugIn. (If the user install the Mach 3 software in C-disk.)

6.2 Open Mach3 Software and connect with right PlugIn file

Double-click the icon mach3mill  . Enter into Mach3 software. Pop-up the plug-in box as below left Figure. Then Click “Create Profile” and name it to “DigitalDream”, click “Default profile values” and confirm it by “OK”

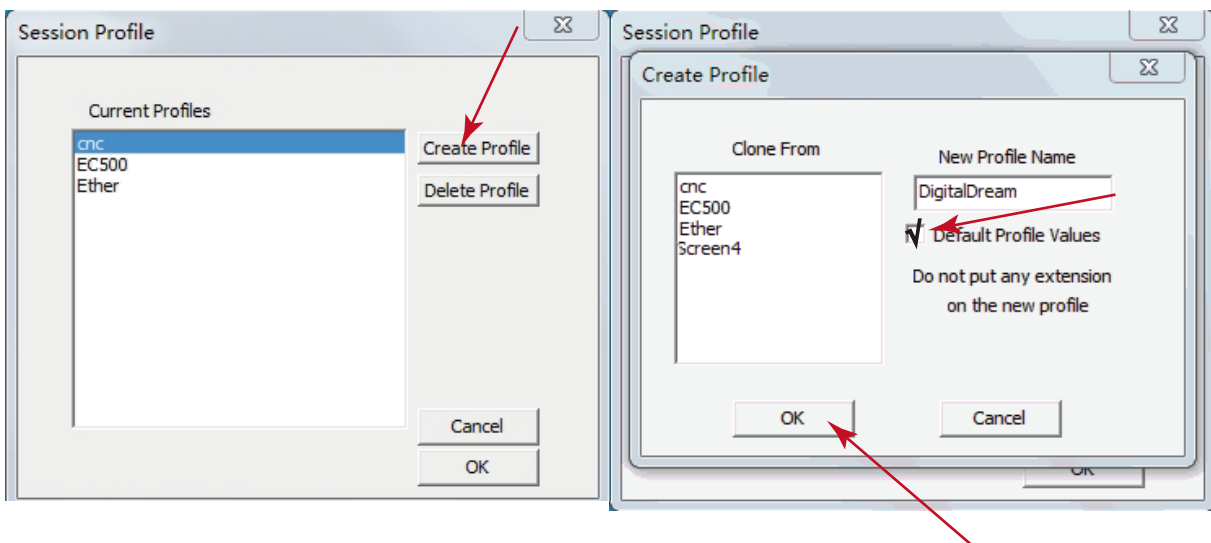

After Click “OK”,it will popup a window of the option for DLL file as below,pls choose “Digital Dream” as below.Then press OK. If you do not want to the dialog box to show again any more, select ‘Don’t ask me this again’.If connect successfully,Status bar will show “UC300 device is connected to your computer”.

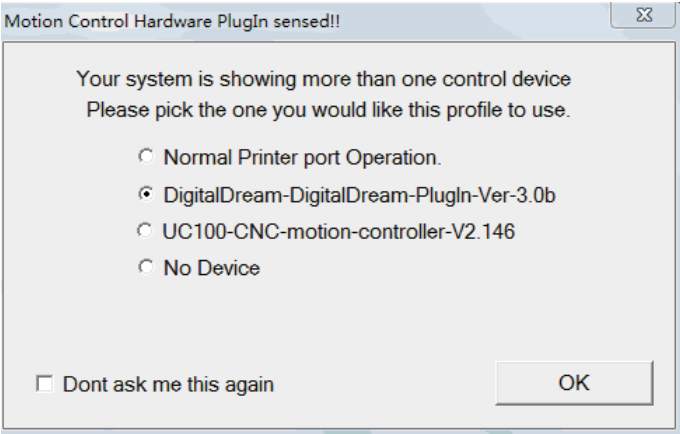

6.3 Check UC300 Plug-In in the Mach3 software

Click config plugins in the software main menu,in the pop-down menu select ‘PluginConfig’,it will show the DigitalDream Plug-In is enabled:

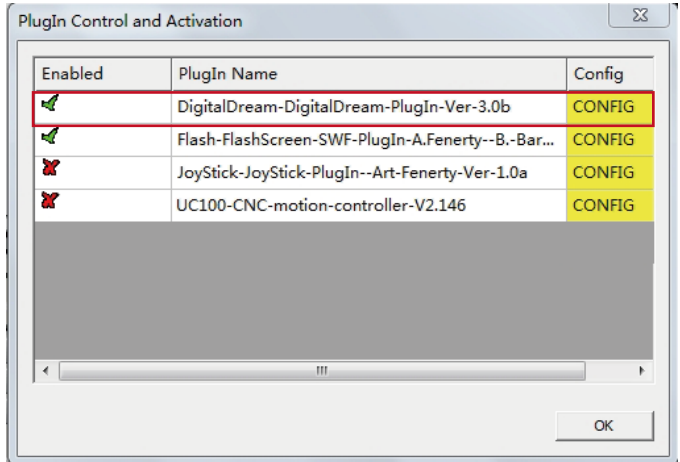

6.4 Motor Tuning and Setup

Click Main Menu 'Config', select the 'Motor Tuning' from its pop-down menu:

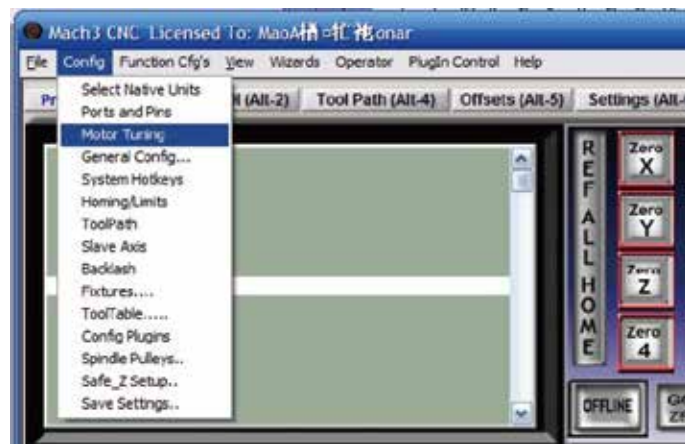

Then the screen display as below:

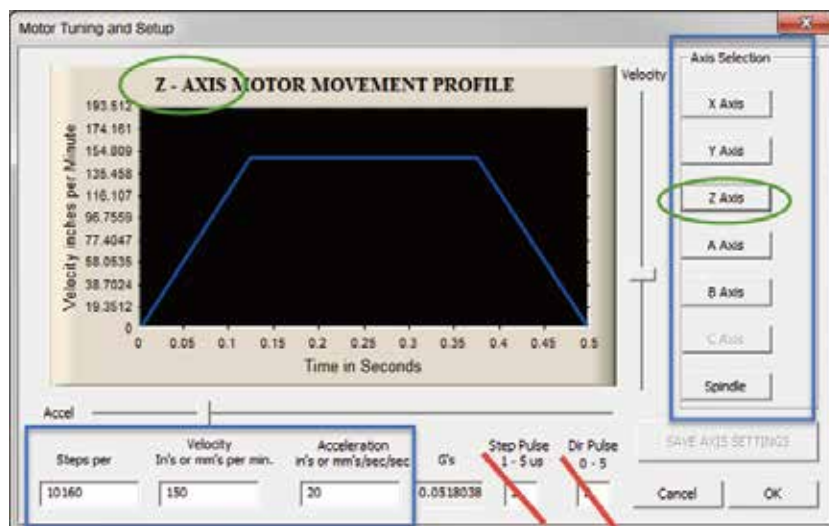

Mach3's Menu -> Config -> Motor Tuning (and Setup).

The Step Pulse and Direction Pulse fields are used for a Ethernet Port connection from your computer to your hardware.

The Steps per Unit, Velocity (Units per Minute) and Acceleration fields are critical for tuning your motors. The Steps per Unit is determined by your hardware for each axis. The velocity is the maximum speed you want your axis to move. The acceleration is the maximum acceleration rate your motors should run at (to prevent stalling or missed steps). This needs to be done for each of your axes.

Don't forget to save the data when you finished the data setting of every axis. For example, you click Z Axis, and save all the data into the column, then you must click "SAVE AXIS SETTING", then the data can be saved.

6.5 Port and Pins Setup

First, make sure you have your Motor Outputs assigned correctly (Menu -> Config -> Ports & Pins as below:

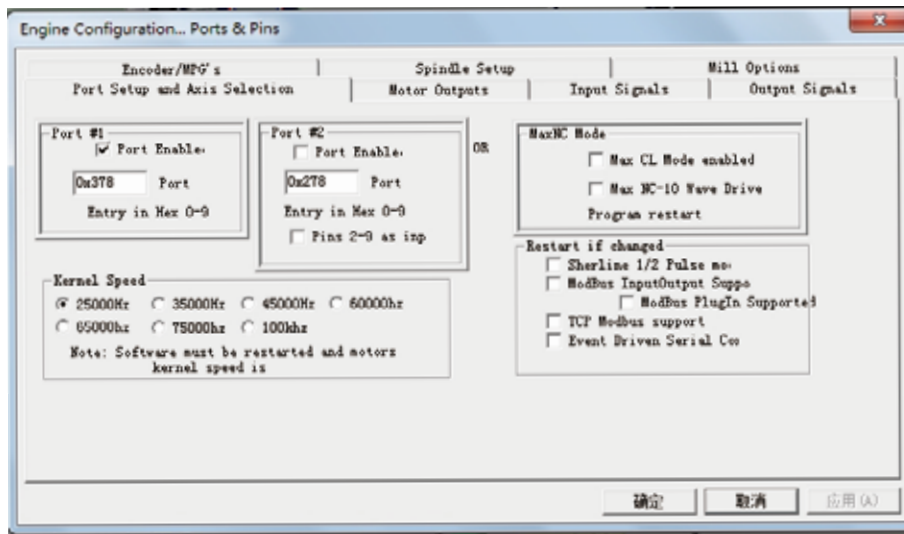

Then go to Right Lables: Motor Outputs and start to configurate as below:

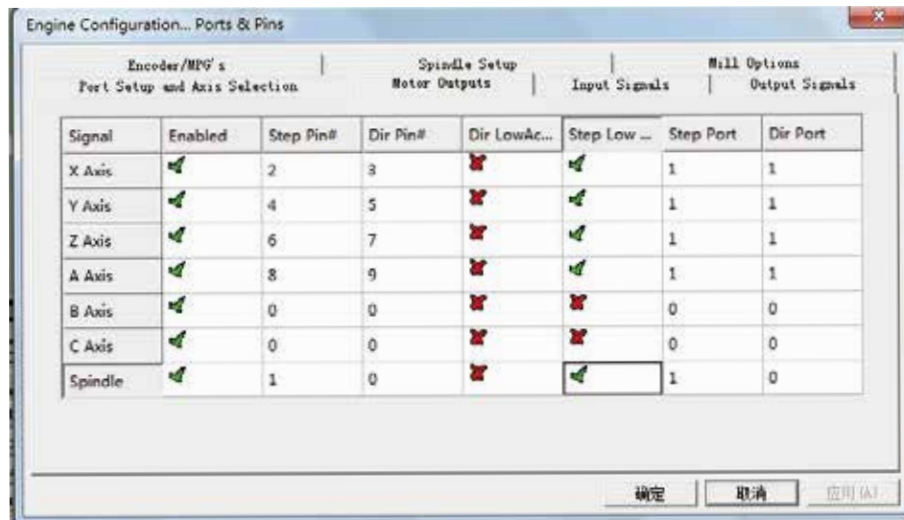

This page is to select the stepper motor control pins. Because Stepper motor control pins address are fixed by the controller board, So here only need to define the Pin address(No.s),we can define other parameters meter. To make sure the Z axis to the right direction(Up is '+',down is '-'), Z axis's "Dir low" should be set to "✓". Other axes's should be set as the user's request.

Second, make sure that you have your home switches assigned correctly (Menu -> Config -> Ports & Pins -> Input Signals). While you could use a single input for your X, Y, Z, and A homes, it is much better to have them as separate inputs! Our UC300 controller has plenty of inputs available and it allows Mach to home all of your axes at the same time if you wish (although you typically have your Z axis home after the rest of your axes so you don't crash your head).

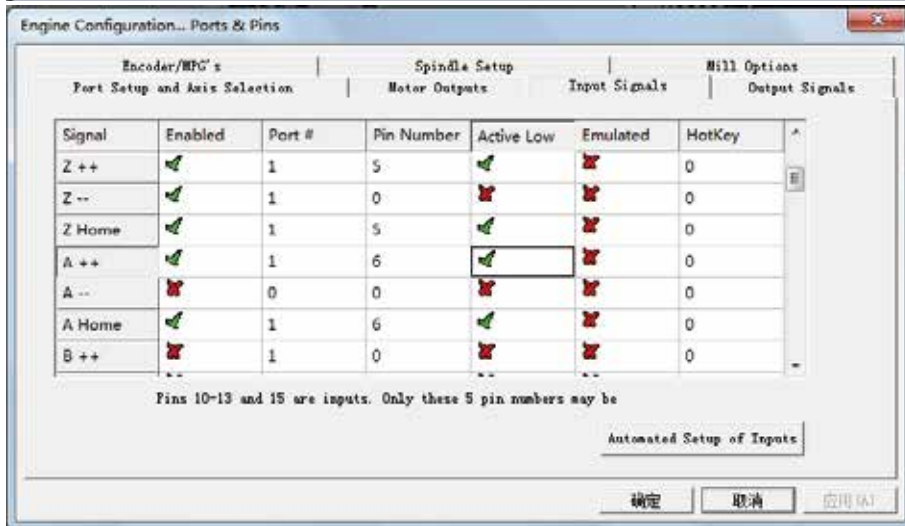
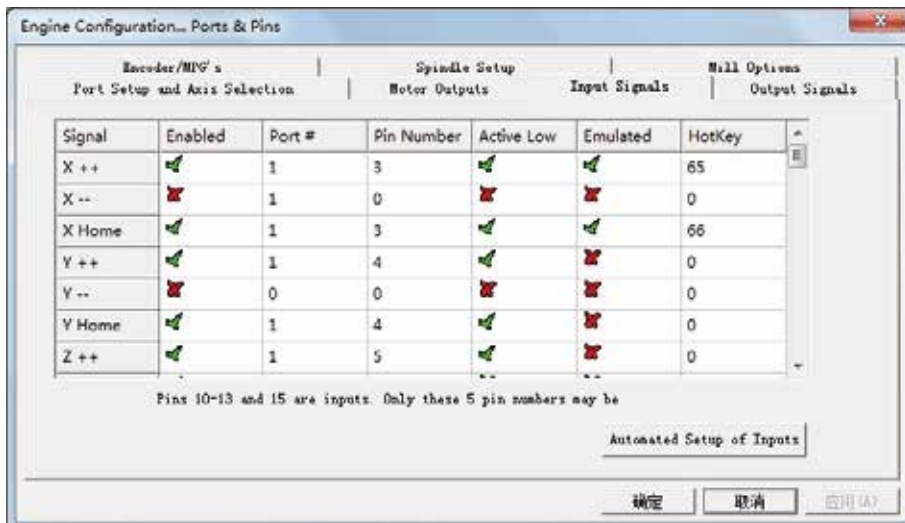

Here you can configure according to your actual needs the corresponding function. Optional Function include XYZABC 6axis's Upper and lower limit、XYZABC 6axis's HOME point. We set upper limit and home of XYZA to 3456 corresponding IN3/IN4/IN5/IN6 of the Controller board.

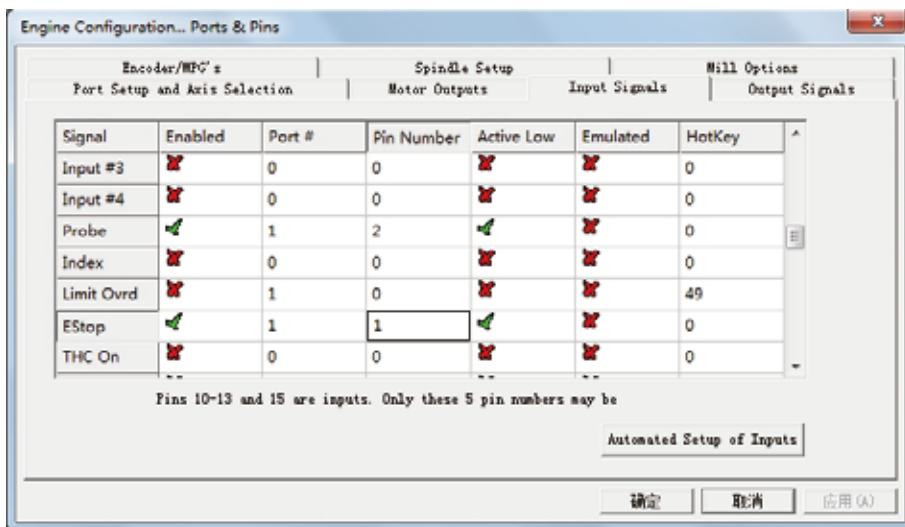

Click “Spindle Setup” switch to the spindle settings page.

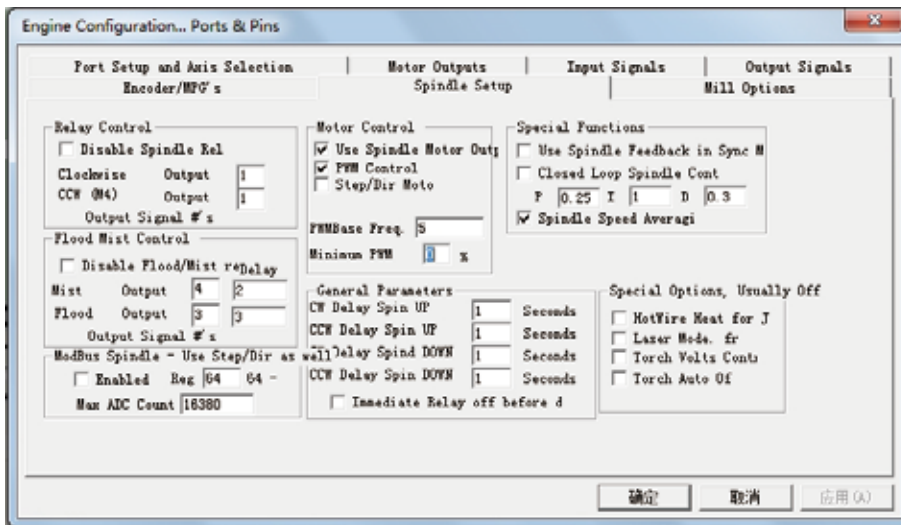

Here we can configure the spindle rotates CW、 Reverse CCW、 Mist、 Flood pin,.They have been configured as 1、 2、 3、 4. Corresponding to output#1~output#4 in Figure4-11.output#1~output#6 in Output Signal Setup dialog can be Configured into these 4 signals. Here we only configure CW/MIST/FLOOD. CW is controlled by OUT1. MIST is controlled by OUT2. Flood is controlled by OUT3. Here we note correspondence between 2 page. Please select “use spindle motor output” if required PWM speed spindle. And select “ PWM Control”. Our PWM pin fixedly arranged on a special pin on Stepper motor setting dialog.

Here by our controller we already define all the Output Ports to Port No. 2.

All Output Ports are defined to Port No. 2.

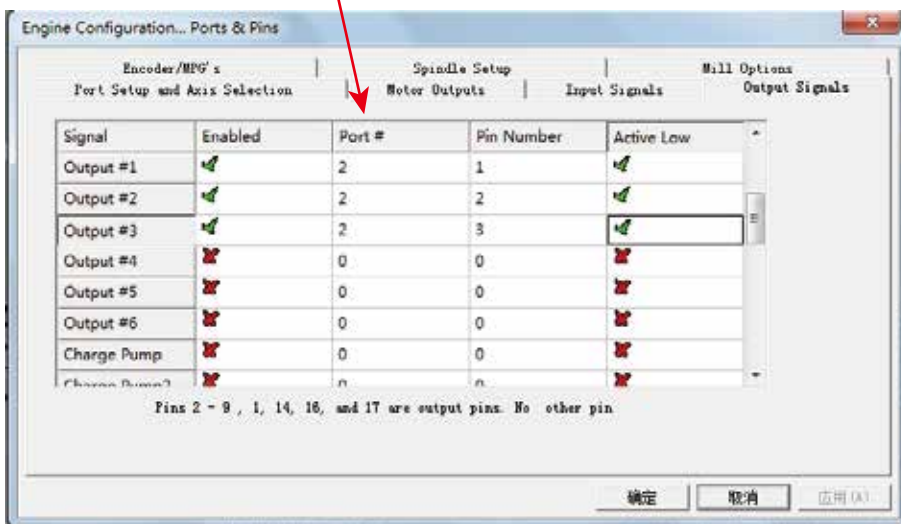

Spindle setting corresponds to the output configuration

6.6 MPG Settings

UC300 only support Standard MPG, Go to Mach 3 and Menu -> Config -> Ports & Pins -> Encoder/MPG's as following.

Port Setup and Axis Selection Encoder/MPG's		Motor Outputs Spindle Setup				Input Signals	Output Signals Mill Options
Signal	Enabled	A -Port #	A -Pin #	B -Port #	B -Pin #	Counts/...	Velocity
Encoder1		0	0	0	0	1.000000	100.0000...
Encoder2		0	0	0	0	1.000000	100.0000...
Encoder3		0	0	0	0	1.000000	100.0000...
Encoder4		0	0	0	0	1.000000	100.0000...
MPG #1		0	0	0	0	1.000000	100.0000...
MPG #2		0	0	0	0	1.000000	100.0000...
MPG #3		0	0	0	0	1.000000	100.0000...

Then to active the MPG function, you can use the hand pulse, under the main page, click TAB to active MPG panel, refer to the following Figure:

